

# Lecture 20 – Passwords and Authentication

Stephen Checkoway

Oberlin College

Slides based on Bailey's ECE 422

**AUTHENTICATION**

# Authentication Basics

- Authentication binds identity to a subject
- Two step process
  - Identification - establish identity to system
  - Verification - process verifies and binds entity and identity

# **PASSWORD AUTHENTICATION**

# Basics

- User keeps a secret string (password)
- Something the user *knows*
- Advantages?
- Disadvantages?

# Attacks

- Steal from the user
  - Install a keylogger (hardware or software)
  - Find it written down
  - Social engineering/Phishing
  - Intercept the password over network
  - Use a side channel
- Steal from the service
  - Install malware on the web server
  - Dump the password database with SQL injection
- Steal from a third party (password reuse)

# Password Guessing

	<b>PIN</b>	<b>Freq</b>
#1	1234	10.713%
#2	1111	6.016%
#3	0000	1.881%
#4	1212	1.197%
#5	7777	0.745%
#6	1004	0.616%
#7	2000	0.613%
#8	4444	0.526%
#9	2222	0.516%
#10	6969	0.512%
#11	9999	0.451%
#12	3333	0.419%
#13	5555	0.395%
#14	6666	0.391%
#15	1122	0.366%
#16	1313	0.304%
#17	8888	0.303%
#18	4321	0.293%
#19	2001	0.290%
#20	1010	0.285%

# Top 20 Passwords (Mark Burnett)

1.	password,	32027	11.	letmein,	3536
2.	123456,	25969	12.	monkey,	3487
3.	12345678,	8667	13.	696969,	3345
4.	1234,	5786	14.	abc123,	3310
5.	qwerty,	5455	15.	mustang,	3289
6.	12345,	4523	16.	michael,	3249
7.	dragon,	4321	17.	shadow,	3209
8.	pussy,	3945	18.	master,	3182
9.	baseball,	3739	19.	jennifer,	2581
10.	football,	3682	20.	111111,	2570



# Power Law

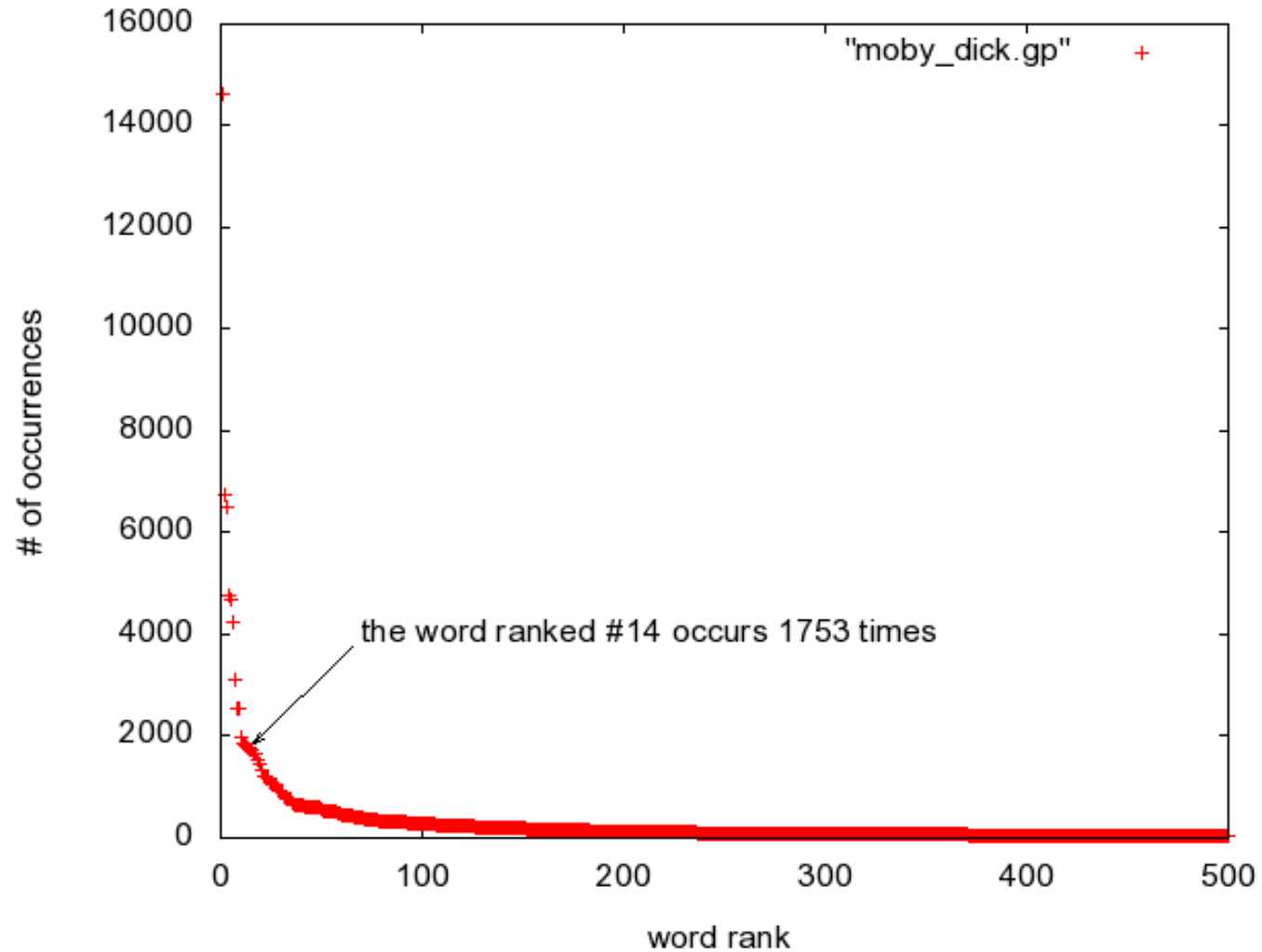

<http://www.philippeadjiman.com/blog/2009/10/26/drawing-the-long-tail-of-a-zipf-law-using-gnuplot-java-and-moby-dick/>

# Secure Passwords

- Uneven distribution makes guessing easier
- Passwords should be uniformly distributed
  - All characters in password chosen with equal probability
- Passwords should be long
  - Longer password = larger brute force search space
- Passwords should never be reused
- Passwords chosen randomly are difficult to remember
  - Tradeoff of security vs. convenience

# **STORING PASSWORDS**

# Confirmed Attack At Opera, 1.7M Password Leak Possible

# Passwords for 32M Twitter accounts may have been hacked and leaked

Posted Jun 8, 2016 by Catherine Shu (@catherineshu), Kate Conger (@kateconger)



Next Story

## Epic Games forums hacked again: Over 800,000 gamers put at risk

BY GRAHAM CLULEY POSTED 23 AUG 2016 - 02:50AM

DATA LEAKAGE

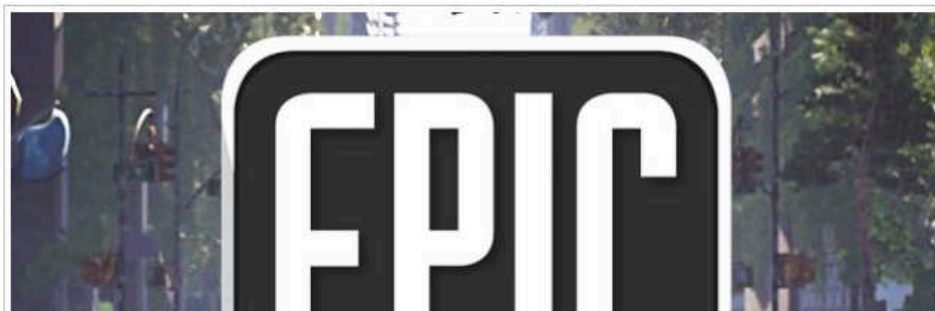

## 43 million passwords hacked in Last.fm breach

Posted Sep 1, 2016 by John Mannes (@JohnMannes)

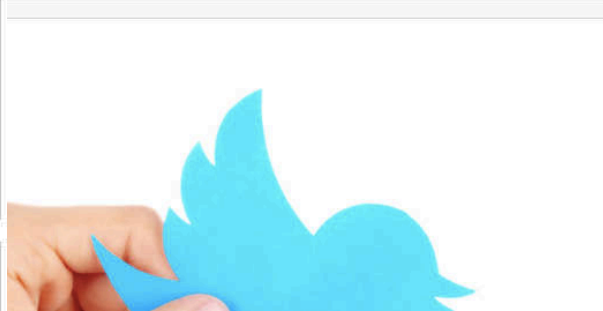

### CrunchBase

Twitter

FOUNDED 2006

#### OVERVIEW

Twitter is a global social networking platform that allows its users to send and read 140-character messages known as "tweets". It enables registered users to read and post their tweets through the web.

## 2016 mega breaches continue as hackers steal and leak 33 million QIP.ru accounts

Breach appeared to have occurred in 2011 and user passwords were allegedly not encrypted.



By India Ashok

September 10, 2016 11:52 BST



## Hackers breach porn site, expose 800,000 user accounts

A massive data breach has invaded the popular porn repository Brazzers' sister site, Brazzers Forum, after hackers took control of the website with nearly 800,000 user account information, including usernames and passwords.

By Yves Matthew Amodia | Sep 13, 2016 09:55 AM EDT

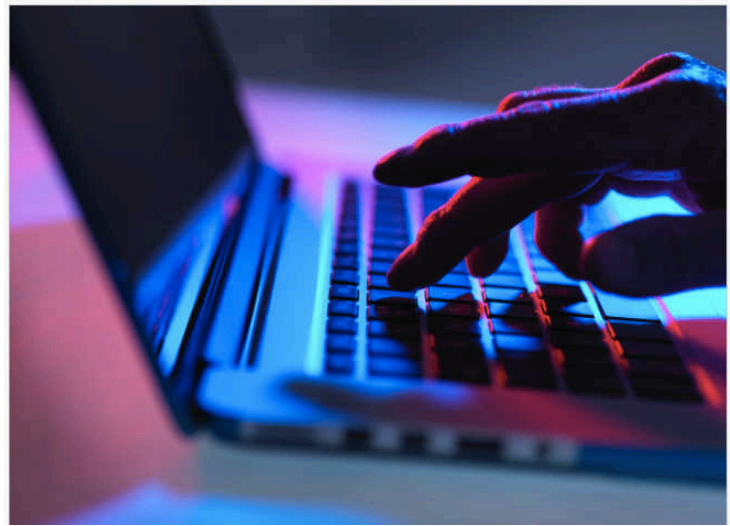

### TC NEWS

**The Daily Crunch**  
Our top headlines  
Delivered daily

**CrunchBase Daily**  
The latest startup funding announcements  
Delivered daily

Enter Address



2012 AVN Adult Entertainment Expo

# Storing Passwords

- Password database is highly sensitive
- We should *never* store *plaintext* passwords
- Store something that lets user prove they know the password

# Hash functions (more later)

- Input – data of an arbitrary size
- Output – fixed length
- Same input always produces the same output
- One way function – cannot deduce input from output
- A “fingerprint” for the input
- Examples: ~~MD5, SHA-1~~, SHA-256, SHA-512, SHA-3
  - `md5("welcome") = 40be4e59b9a2a2b5dfffb918c0e86b3d7`
- ***None of these should be used directly used for password hashing***

# Noncryptographic hash functions (and more)

- Cyclic redundancy checks (CRC)
  - CRC-16, CRC-32, etc.
  - Based on polynomials, many variants
- Checksums
  - sum-8, sum-16, Adler-32, Luhn algorithm, etc.
- Noncryptographic hash functions
  - FNV-1, Bernstein hash (djb2), Java's hashCode()
- ***None of these should be used used for password hashing***

# Password Hashes

- We store a database of password *hashes*
- e.g., /etc/shadow on UNIX

```
rcunnin2:$6$vb1tLY1qiY$M.1ZCqKtJBxBtZm1gRi8B  
bkn39KU0YJW1cuMFzTRANcNKFKR4RmAQVk4rqQQCkaJT  
6wXqjUkFcA/qNxLyqW.U/:15405:0:99999:7:::
```



# Password Cracking

- Brute force search through all possible passwords in order
- Use a dictionary
- Use a dictionary of common passwords
- Combine dictionary with common passwords and heuristics (e.g. p@\$\$w0rd and password123)
- Use statistical models of user passwords
- Easy to parallelize: hash password guess, compare to entire hash database
- Commonly done with arrays of GPUs

# Rainbow Tables

- Many passwords are common
- Precompute them in a lookup table
- Time/space tradeoff

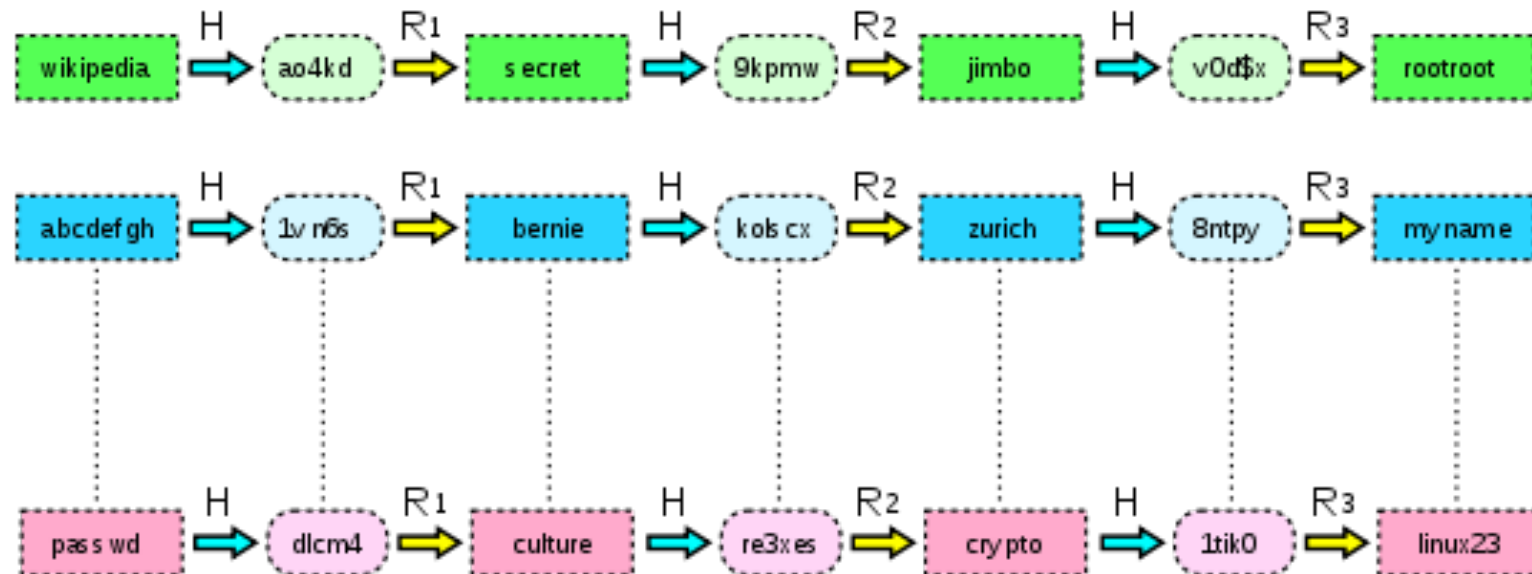

# Salting Password Database

- Generate and store a random number, the salt for each password
- Concatenate password and salt to compute hash
- Effectively a unique hash function for each password

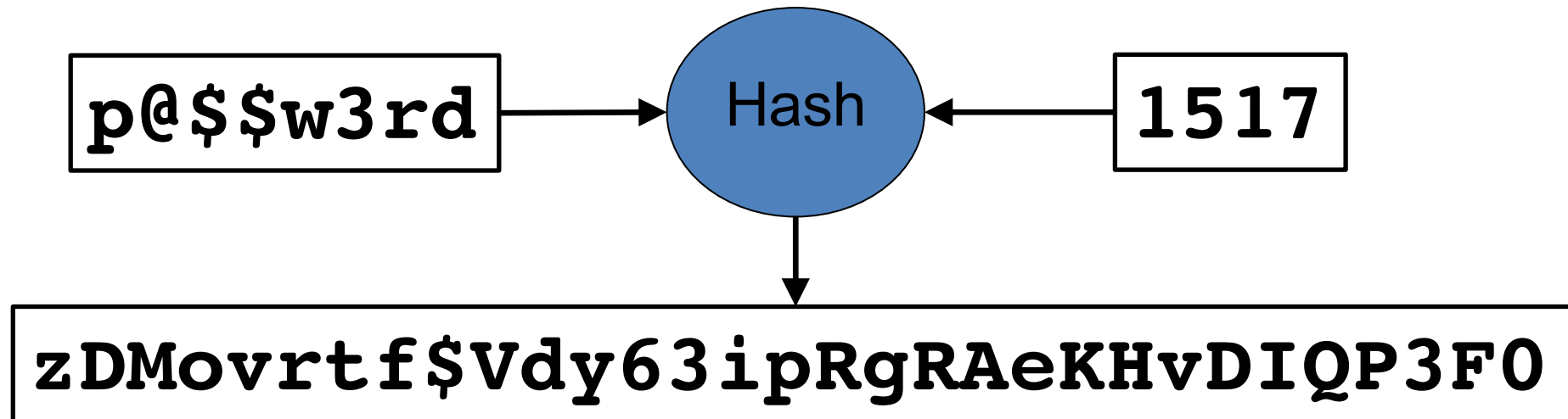

# Password Security Policies

- Educate users about password security
  - Specifically train them to use good passwords
  - But they might or might not follow through
- Generate passwords randomly
  - Perfect uniform distribution
  - But not very psychologically acceptable
- Reactive password checking
  - Crack your own user's passwords
  - But expensive and passwords vulnerable until cracked
- Complex password policy/proactive checking

# Complex Password Policy/Proactive Checking

- Let the user select their own password
- Force them to follow a policy
- Reject passwords that don't follow policy
- But...
  - Technically *reduces* number of possible passwords
  - Policy might not be psychologically acceptable
  - We don't know if users are reusing their passwords

# Security Questions

- Are also a shared secret
- Bruce Schneier calls them “a backup password”
- Easier to guess and social engineer
- Some cannot be changed
- Some websites have a fixed set of answers!



# Breaches happen

- Databases of usernames and passwords are exposed
- <https://haveibeenpwned.com/> ← Use this!

THE VERGE

TECH ▾

SCIENCE ▾

CULTURE ▾

CARS ▾

REVIEWS ▾

LONGFORM

VIDEO

MORE ▾

US & WORLD

TECH

CYBERSECURITY

## Yahoo says all 3 billion user accounts were impacted by 2013 security breach

by Natt Garun | @nattgarun | Oct 3, 2017, 5:07pm EDT

f SHARE

🐦 TWEET

in LINKEDIN

# **RECENT PASSWORD SOLUTIONS**



# Password Managers

- Application that generates and maintains passwords
- Examples: Browsers, LastPass, KeePass, DashLane, 1Password
- Advantages:
  - Can handle random passwords
  - **Can create unique passwords for every website and service**
- Disadvantages
  - One point of failure
  - Requires a strong password (could be snooped)
  - Could be hacked (only as secure as the password manager)
  - Inconvenient (doesn't work for some sites, set up time, etc.)

# One Point of Failure...

## Trend Micro password manager had remote command execution holes and dumped data to anyone: Project Zero

Google's Project Zero discovered multiple trivial remote code execution vulnerabilities sitting within a password manager installed by Trend Micro as default alongside its AntiVirus product.



By [Chris Duckett](#) | January 12, 2016 -- 01:32 GMT (17:32 PST) | Topic: [Security](#)



A password management tool installed by default alongside Trend Micro AntiVirus was

### RELATED STORIES



Security  
**ClixSense data breach exposes personal information of million of subscribers**

# Single Sign-On (SSO)

- Login to trusted 3rd party (identity provider), who vouches for user identity
- Examples: Facebook Connect, OAuth, OpenID Connect
- Pros and cons similar to Password Managers
- Third party can track users...

# **TOKEN-BASED AUTHENTICATION**

# Basics

- Something the user *has*
- Static memory cards
  - Read only
  - e.g. ATM card/Credit Card
  - Vulnerable to replay attack
- Smart card
  - Storage and computation
  - Enables challenge-response or one-time password
  - Protects against replay attack

# Challenge-Response

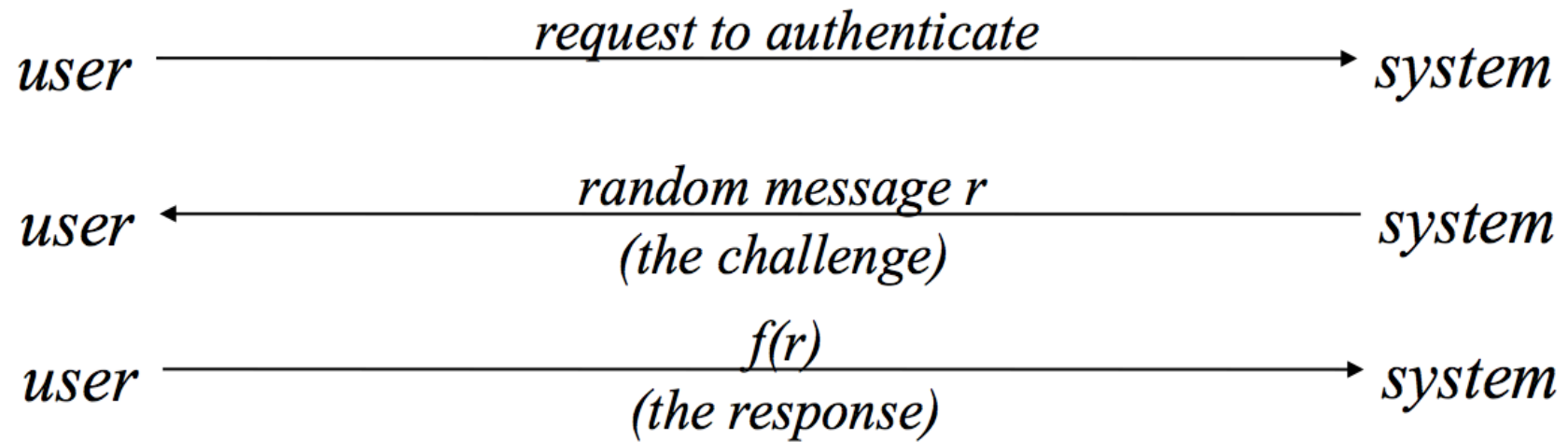

# One-time password (OTP)

- Smart card can also implement one-time password scheme
- S/Key is one such scheme
- Time-based one-time password is another (TOTP)
- Vulnerable to man-in-the-middle (MitM)

# S/Key

- Server
  - Generates random seed  $S$
  - Computes  $H(S), H^2(S), H^3(S), \dots, H^{n+1}(S)$  and gives the first  $n$  of them to the client in reverse order
  - Server stores  $H^{n+1}(S)$  and discards the rest
- To authenticate
  - Client sends the first unused value  $P$  (initially  $P=H^n(S)$ ) to the server
  - Server computes  $H(P)$  and compares to the stored value
  - If there's a match, the client is authenticated and discards  $P$ ; the server discards the stored value and stores  $P$  in its place



# TOTP

- The current time is turned into time-counter TC
  - $TC = \text{floor}(\text{now} - \text{start\_time}) / \text{time\_step}$
- TC and a secret key are used to create TOTP
  - $\text{TOTP} = \text{HOTP}(\text{secret\_key}, TC)$
  - HOTP is based on a keyed-hash function
- The output is  $\text{TOTP} \bmod 10^d$  for d digits
- Client and server both compute the output value based on the current time and the client sends it to the server

# One-time Password MitM

1. User sends username/password to phishing site
2. Phishing site forwards them to legitimate site
3. Legitimate site asks phisher for OTP
4. Phishing site asks user for OTP
5. User sends OTP to phisher
6. Phisher sends OTP to legitimate site

# One-time Password MitM

- What's the problem?
  - OTP not bound to the website it is sent to
  - OTP can be replayed
- What's the solution?
  - Bind the OTP to the specific website
  - Then OTP sent to bankofthev**v**est.com can't be sent to bankofthe**w**est.com (for example)

# Universal second factor (U2F)

- Addresses OTP's weakness to MitM
- Website's *origin* is cryptographically bound to the response (not displayed in the diagram)

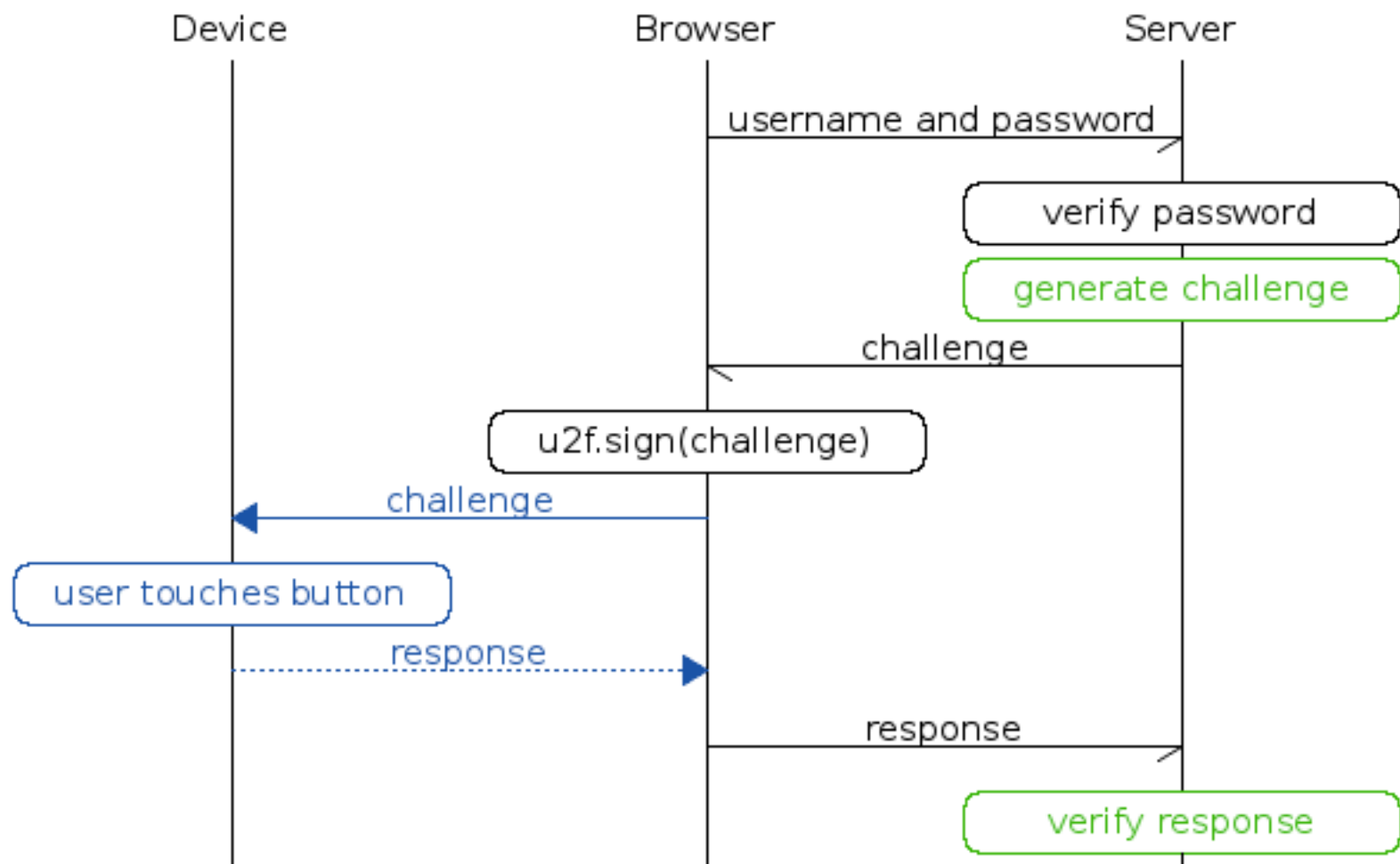

# Disadvantages

- Token can be lost, stolen, or counterfeited
- Requires an individual physical token
- Requires an extra step (mildly inconvenient)
- Hardware can be expensive...
  - ...but usually isn't
  - \$20 for U2F key from Yubico
  - Google, Facebook, and Yubico were all giving these away at a recent conference I attended (pre-pandemic!)

# **BIOMETRIC AUTHENTICATION**

# Biometrics

- Something the user *is* or *does*
- Derive a signature from biological features of user
  - Voice, fingerprint, face, retina, handwriting, gait
- Advantages?
- Disadvantages?

# Disadvantages

- Imprecise measurements require *approximate* matching
  - Essentially a machine learning task
  - False negatives *and* false positives have a cost
- Measurements change over time
- Poor accessibility
- Cannot be replaced or concealed
- Replay attacks/spoofing possible
- Can be legally compelled to provide biometrics



# OPM Breach

## KrebsonSecurity

In-depth security news and investigation



[BLOG ADVERTISING](#)

[ABOUT THE AUTHOR](#)

## Congressional Report Slams OPM on Data Breach

A massive data breach at the U.S. Office of Personnel Management (OPM) that exposed background investigations and fingerprint data on millions of Americans was the result of a cascading series of cybersecurity blunders from the agency's senior leadership on top of the outdated technology used to secure the sensitive data, according to a lengthy report released today by a key government oversight panel.



My New Book!



# Facial Recognition

[Browse Journals & Magazines](#) > [IEEE Transactions on Informat...](#) > [Volume: 9 Issue: 7](#) [?](#)

## Spooing Face Recognition With 3D Masks

**Purchase or Sign In**  
to View Full Text

**14**  
Paper  
Citations

**1588**  
Full  
Text Views

### Related Articles

Face  
Verification  
With Local  
Sparse  
Representation

3D Assisted  
Face  
Recognition:  
Dealing With  
Expres...

Depth  
Estimation of  
Face Images  
Based on the  
Cons...

**2**

Author(s)

▼ Nesli Erdogan ; ▼ Sébastien Marcel

[View All Authors](#)

**Abstract**

[Authors](#)

[Figures](#)

[References](#)

[Citations](#)

[Keywords](#)

[Metrics](#)

[Media](#)

### Abstract:

Spooing is the act of masquerading as a valid user by falsifying data to gain an illegitimate access. Vulnerability of recognition systems to spooing attacks (presentation attacks) is still an open security issue in biometrics domain and among all biometric traits, face is exposed to the most serious threat, since it is particularly easy to access and reproduce. In this paper, many different types of face spooing attacks have been examined and various algorithms have been proposed to detect them. Mainly focusing on 2D attacks forged by displaying printed photos or replaying recorded videos on mobile devices, a significant portion of these studies ground their arguments on the flatness of the spooing material in front of the sensor. However, with the advancements in 3D reconstruction and printing technologies, this assumption can no longer be maintained. In this paper, we aim to inspect the spooing potential of subject-specific 3D facial masks for different recognition systems and address the detection problem of this more complex attack type. In order to assess the spooing performance of 3D masks against 2D, 2.5D, and 3D face recognition and to analyze various texture-based countermeasures using both 2D and 2.5D data, a parallel study with comprehensive experiments is performed on two data sets: the Morpho database which is not publicly available and the newly distributed 3D mask attack database.

# **OTHER SCHEMES**

# 2 Factor Authentication (2FA)

- Something you **have** AND something you **know**
- Either factor is useless without the other
- Chip and PIN
- Commonly implemented in mobile phones via SMS
  - Disadvantages:
    - ONE device (if hacked)
    - SMS is easy to redirect
    - ONE point of failure for SE (phone company)
- Google authenticator, Duo Mobile, Authy, Yubico Authenticator
- OTP tokens (e.g., TOTP), U2F keys

# Multifactor Authentication

- Next level 2FA
- Combination of biometrics, knowledge, and possession

# Behavior Profiling

- Track access behavior of users
  - Systems used
  - Times and locations when active
  - Typical usage
- Look for anomalous or fraudulent behavior
- “Why is this person who was in Iowa 2 minutes ago logging in from Nigeria?”
- Used in fraud prevention